

Axial-flow pump, vertical design

KUNST 125 AFV-118 / . . / 2 - YL - 001

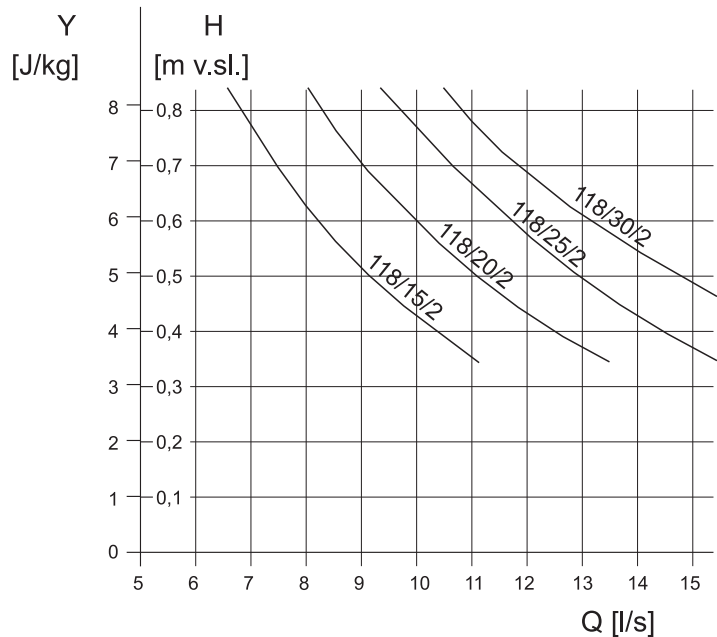
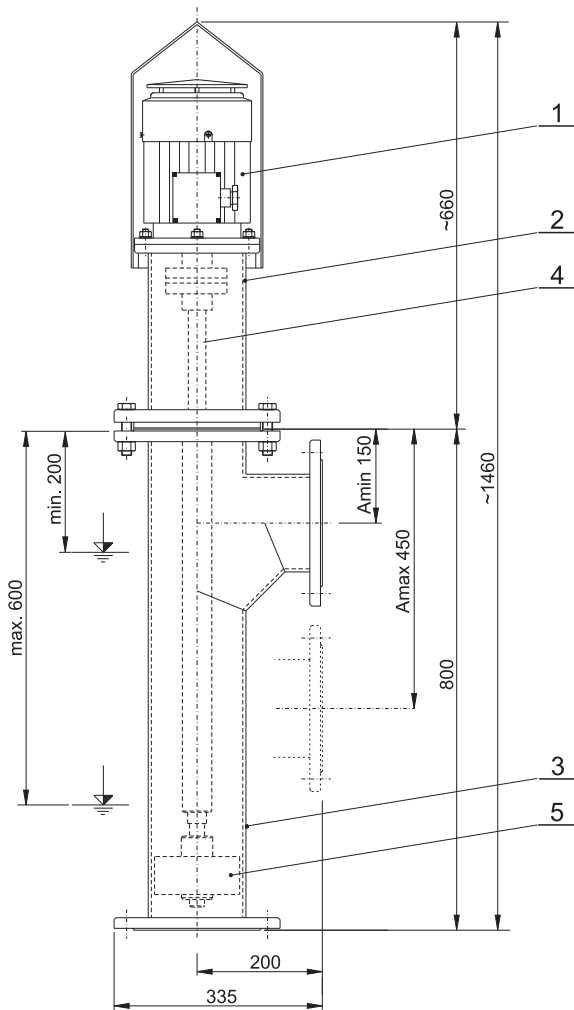

LEGENDA:

1. Electromotor
2. Lantern
3. Pump casing
4. Shaft
5. Impeller

TABLE OF MAIN DIMENSIONS:

Pump Typ	Electromotor Typ	P	U	f	Revolutions n	Connections		Weight
						suction	delivery side	
125 AFV - 118 / 15 / 2	4 AP 80 - 4	0,75 kW	400 V	50 Hz	1380 min ⁻¹	IP 54	DN 125, PN 2,5/6	50 kg
125 AFV - 118 / 20 / 2	4 AP 80 - 4	0,75 kW	400 V	50 Hz	1380 min ⁻¹	IP 54	DN 125, PN 2,5/6	50 kg
125 AFV - 118 / 25 / 2	4 AP 80 - 4	0,75 kW	400 V	50 Hz	1380 min ⁻¹	IP 54	DN 125, PN 2,5/6	50 kg
125 AFV - 118 / 30 / 2	4 AP 80 - 4	0,75 kW	400 V	50 Hz	1380 min ⁻¹	IP 54	DN 125, PN 2,5/6	50 kg

R.č. KAVČ 125-K 02/08-A-en



Axial-flow pump, vertical design

KUNST 125 AFV-118 / . . / 2 - YL - 001

APPLICATION

The axial-flow pump in vertical design is used to convey recycle and excess sludge, or for recirculation of sludge on a waste water treatment plant. The pump can operate continuously or discontinuously. The pump is designated for outdoor usage and is designed to fit vertical pipes. Generally the medium needs to be pumped over short distances and low height (approx. 1m Water column). Rating the pump accuracy is necessary, considering the dimensions of suction and delivery side of the pump as well as the head loss. Velocity on the suction and delivery side may not be lower than 0.6 m.s-1. On the delivery side of the pump, the pipe needs to be installed having a down-grade of 5% or more. To choose the correct impeller diameter it is necessary to determine the operating point using Q-H-Diagrams. Considering the difference in height of the tank level and the lantern, the inlet may be guided or underneath the surface level of the medium. The pump layout enables installation of the pump in water containing as well as waterless tanks. The pump is not dedicated to convey mire polluted water, sand or abrasive solids, oil or hydrocarbons.

Temperature of pumped fluid	+50°C through +400°C
Max. density of fluid	1020 kgm-3
pH range	6 – 8.5
Operating position	vertically
electromotor system of protection	IP 54
electromotor insulation class	F

PARAMETERS

The standard impeller configuration is 118/15/2, 118/20/2, 118/25/2 and 118/30/2. From the operating curve, it is possible to determine parameters Q and H for a chosen impeller.

MATERIAL DESIGN

The standard version of the material is chemical resistant steel without further coat painting. The shaft is made of construction steel, the clutch and electromotor are manufactured according to standards. The pump is delivered including a packing box, initial fill of oil and oil level gauge. At delivery, the connections on suction and delivery side are covered with a plastic blind flange.

OPERATION AND MAINTENANCE

The operation of the facility does not require constant care. Their maintenance is in accordance with the instructions of operation.

DELIVERY FORM

Generally the pump is delivered as a part of equipment of the final settling tank KUNST DN-5-K through DN-6-K or according to contract.

DELIVERY DATE

According to contract

R.č. KAVČ 125-K 02/08-A-en

